

Pedestrian Gates

MPS 122

The MPS series is designed to control pedestrian access in basic security applications with surveillance. It may also be used as supplement to other Magnetic pedestrian gates, in particular to provide passage for wheelchairs and for persons carrying large items.

The MPS pedestrian gate consists of a tube with two or three brackets for mounting barrier elements. These can be standard elements (see picture), glass or customer-specific elements.

The MPS series can be used in bidirectional applications to control the entry and exit with only one gate.

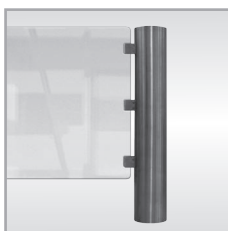
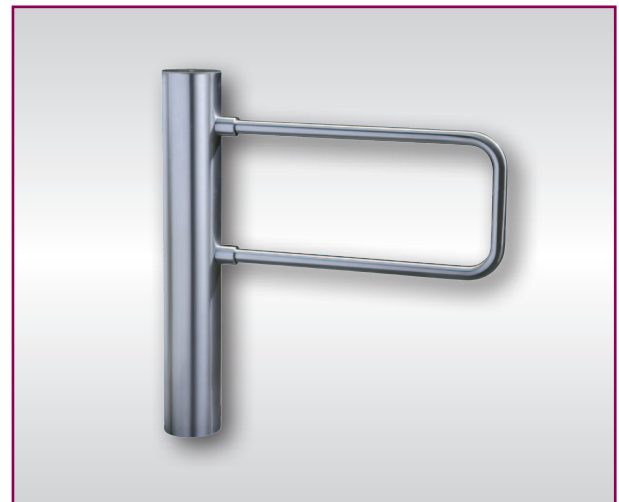

Housing and quality

The housing (column) is basically a polished, grade 1.4301 (V2A) stainless steel tube with a diameter of 159 mm, which provides degree of protection IP 44. The drive unit is concealed within the housing and rotates the outer stainless steel tube. This rotatable part of the gate has two or three brackets for mounting barrier elements. These can be standard rails, glass flaps (toughened safety glass or laminated glass), or customer-specific barrier elements.

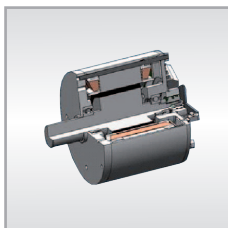

Motor and control unit

The key component of the MPS drive is the highly dynamic MHTM™ motor with precision position feedback. The major feature of this motor is its high torque combined with harmonic opening and closing motions. This ensures fast acceleration and braking, and, at the same time, low forces and improved safety. The MBC-110 logic controller offers adjustable speeds and opening times. The opening angle is adjustable over a wide range from 10° to 300°.

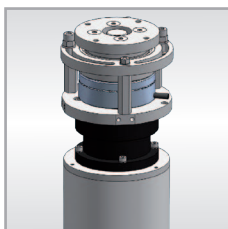

Locking / vandalism protection

An electromagnetic dog clutch allows the barrier to be locked in small steps; the positions are determined by the toothed clutch. This prevents the barrier from being forced out of its end position or moved against the released direction of passage. In the event of panic or vandalism, protection and safety are ensured by a force limiter. In the event of a power failure or in an emergency, the dog clutch opens to provide free passage.



Safety

The intelligent drive system recognises persons or objects in the swept zone during opening / closing. The behaviour of the barrier after contact with an obstacle is adjustable.

MPS swing gates are available in a version with approval for use in emergency exits and rescue routes.

Technical data
MPS 122

Drive unit	MHTM™
Voltage	110/115/230/240 V AC
Frequency	50-60 Hz
Power consumption	45 W
Opening / closing time	1.5 - 4.0 ¹
Opening angle, works settings	2 x 90°
Height	1000 mm
Diameter	159 mm
Weight	40 kg
Protection class	IP 44
Temperature range	-25 to +45° C ²

¹ Depending on dimensions

² With heating activated

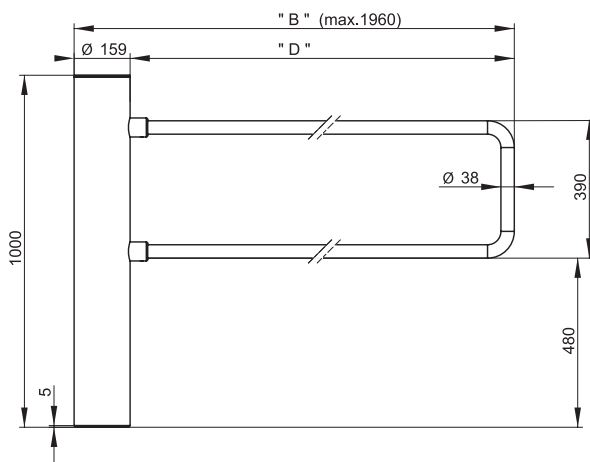
Dimensional drawing with U-shaped rail

Dimensional drawing with glass flap
