

Operating Instructions

Pedestrian Turnstile

Type MPT 33

Contents

1. Delivery	2
2. Safety.....	2
3. Description and operation	3
4. Foundation	4-5
5. Assembly and installation.....	6-9
6. Electrical connection	10-11
7. Access control devices.....	12
8. Options.....	13
9. Commissioning.....	14
10. Technical support.....	14
11. Spare parts and accessories.....	14-15
12. Warranty	16
13. Controller MSC 10.....	20-22

1. Delivery

The Security Turnstile consists of:

- 1 x Semi cage made of stainless steel or mild steel
- 1 x Center column 3 x 120°, stainless steel or mild steel
- 1 x Top housing with locking unit
- 1 x U-bar locking unit
- 1 x Electronic controller MSC10
- 1 x Set of documents inside the lockable top cover
- 1 x Fixing achors (in Europe only)
- 2 x Keys for the top cover

Technical Data:	Typ	MPT 33
Protection	IP	54
Voltage VAC		230
Frequency	Hz	50
Current	A	2,5
Duty Cycle	%	100
Weight	Kg	320
Height	mm	2230
Diameter	mm	1300

2. Safety

2.1 General safety notes

The Magnetic pedestrian turnstile has been designed, built and tested according to the latest technology. Although it has left the factory in a fully operational and safe condition, it is important that the installation is carried out correctly therefore the operating instructions must be read carefully and the safety notes must be observed.

Any liability and warranty is declined by the manufacturer in the case of incorrect use and use for purposes other than intended.

2.2 Use for the intended purpose

The Magnetic pedestrian turnstile may be used only to control pedestrians entering or exiting restricted areas, usually under surveillance.

The Magnetic Universal Controller may be used only for controlling the Magnetic pedestrian turnstile. Any other use is not permitted.

Conversions and modifications to the turnstile or to the control modules are not permitted.

Only original spare parts and accessories from Magnetic may be used.

2.3 Identification of risks

Possible risks and notes are identified with the following symbols in the operating instructions:



Warning!

This symbol in the operating instructions identifies actions and conditions which can give rise to danger for life and limb of persons. Observe the instructions carefully.



Caution!

All actions and conditions which can possibly give rise to damage to objects are identified with this symbol in the operating instructions. Observe the instructions carefully.



Note!

Relevant and useful notes for the user are identified with this symbol.

2.4 Safety notes

- Disconnect all external opening or closing devices (remote control, control desk, etc.) during maintenance work
- It is prohibited to install the barrier without proper mounting to the foundation
- A main power switch or residual current operated device is compulsory
- Risk of bodily harm while cover is open
- Pedestrian barriers are maintenance free
- Documentation should be easily accessible.
- Before commissioning make sure all electrical and functional features are tested.
- Permissible environmental conditions
- The electrical wiring of the barrier must comply with the included drawings.
- Only certified and trained electrical technicians may perform the electrical connections
- Only certified and trained electrical technicians may remove covers for mains plug, mains receivers or wirings
- Before repairing electrical failures disconnect fuse
- Risk of bodily harm if while closing the cover
- During maintenance work the fixing bolt must be checked and tighten, if necessary.
- Current carrying components like transformers, solenoids, resistors, stator housings of motors, lamps etc. shall not be touched while in operating-temperature condition; this can cause skin burns

3. Product description

The MPT series of turnstiles are designed to control pedestrians entering or exiting restricted areas outside in high security situations. The turnstile consists of four different component parts (see fig. 1) It can be used for bi-directional access control by means of keys or card readers (access control devices in general). Entry and exit of the barrier can either be operated in open, controlled or closed modus. The rotating centre column consists of 3 x 120 degree U bars. The controller, the drive units and the locking device are mounted on top of the centre unit in a powder coated sheet metal enclosure, where there is also space for additional access control equipment. Locking and release of the centre is realized by an electro-mechanical locking device with solenoids.

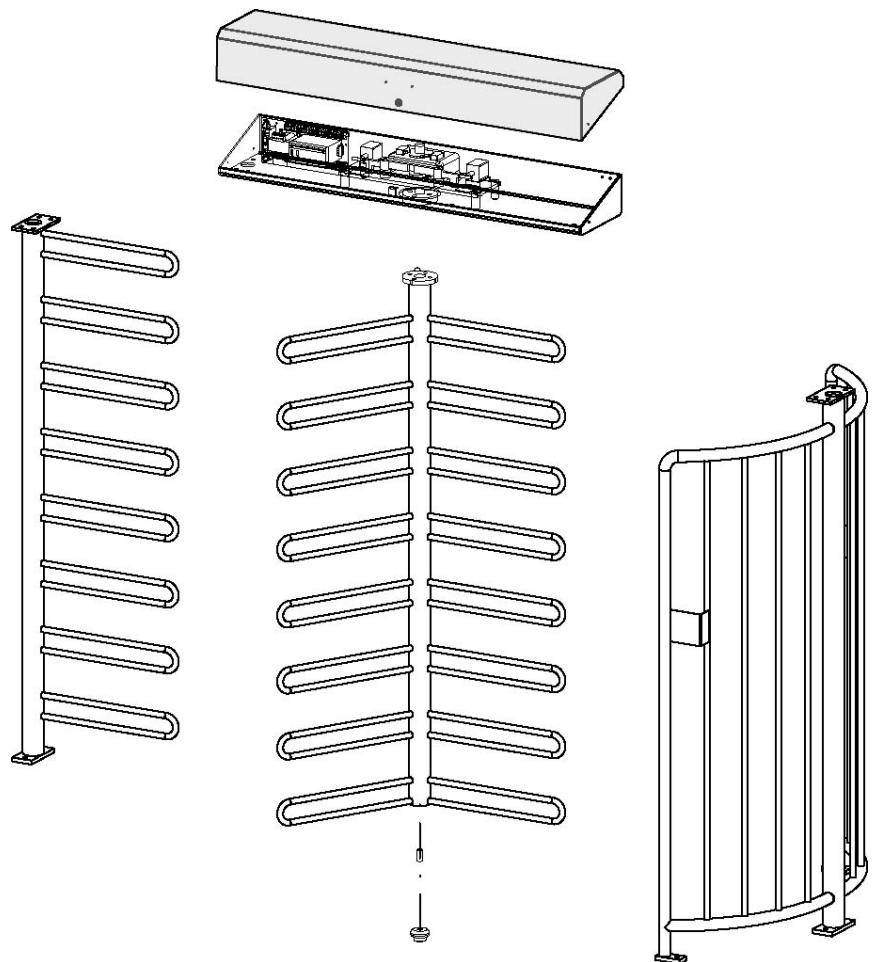

Fig.1

4. Foundation

A level concrete mounting surface is required to secure the turnstile housing. For the dimensions please refer to figure 2. The cables should finish a minimum of 5 meters above the finished concrete surface.

NOTE: This foundation is also required in connection with a foundation frame.

Conduits for mains supply and data lines should finish 50 mm approx. above foundation

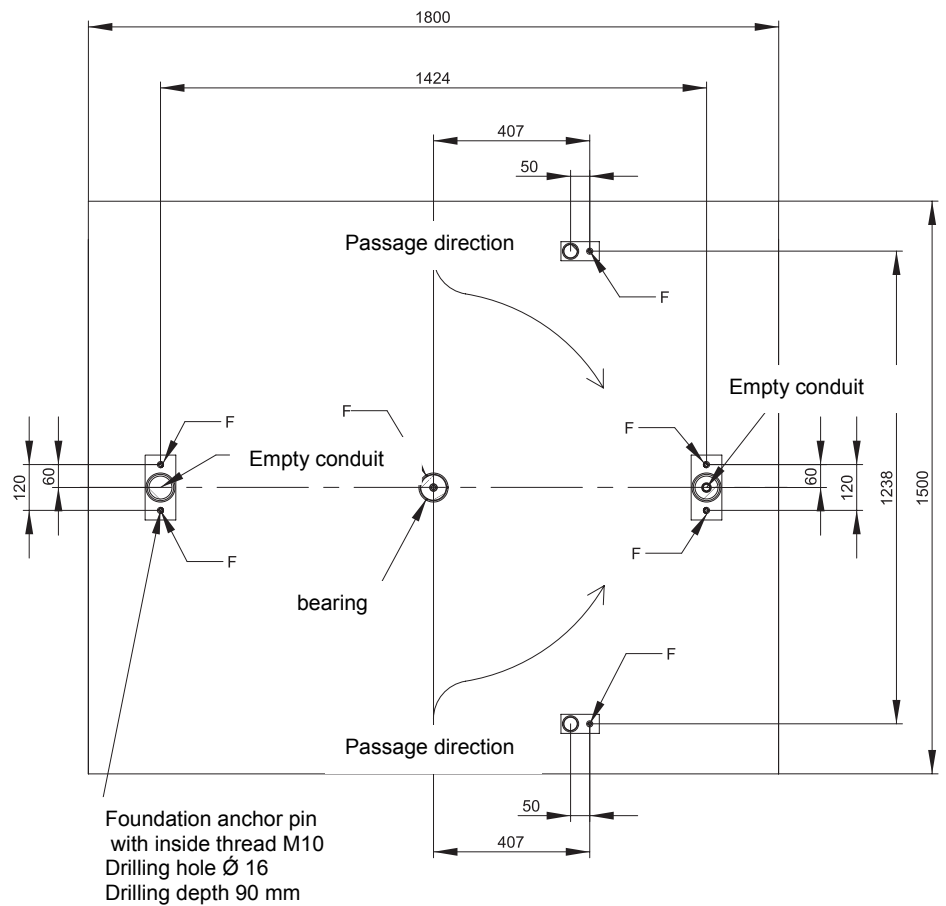

Fig. 2

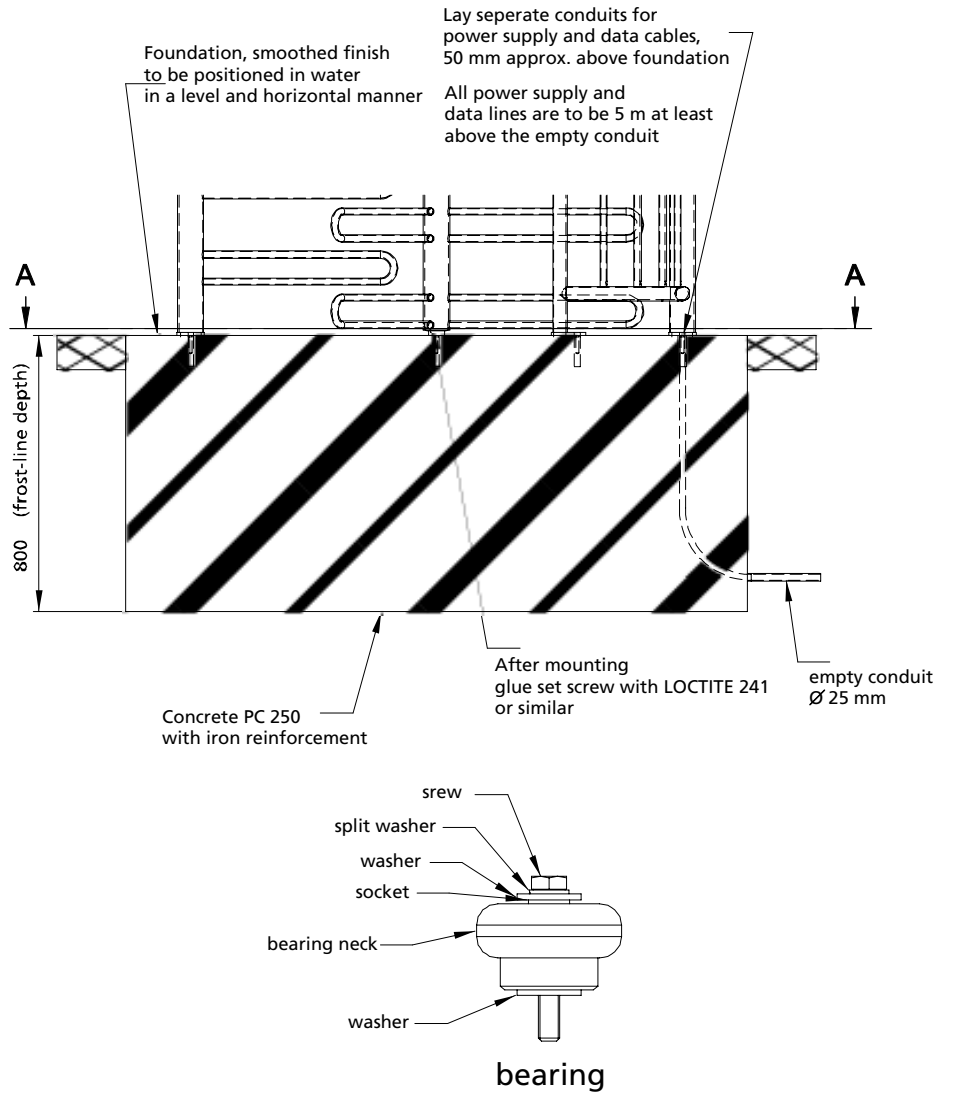

Fig.3

4.1 Foundation frame

The foundation frame is required for turnstiles to be mounted on a subground, for example in case of pavers. A level concrete mounting surface is required for correct mounting of the foundation frame. It should be 150 mm approx. below the finished surface. Mounting of the foundation frame: correct positioning of foundation frame, drilling of fixing holes, install fixing bolts, lay the foundation frame into water by means of jackscrews and tighten the foundation frame.

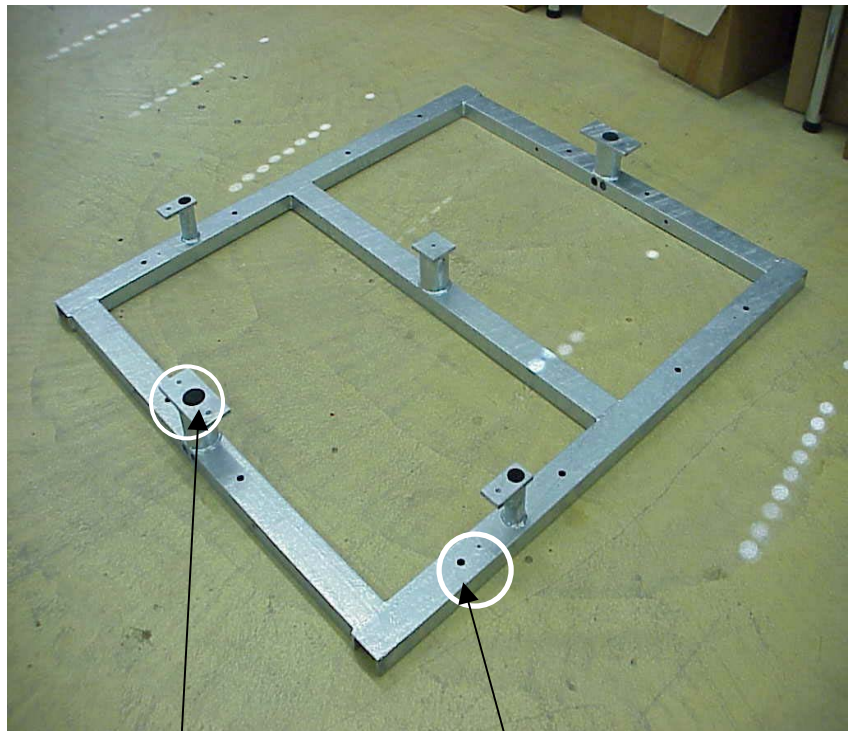

Fig.4

Cable routing from foundation into turnstile

Jackscrews
For positioning the foundation
Frame on the concrete, if necessary.

5. Assembly and installation

5.1 To fit the turnstile (above ground foundation)



- The turnstile should be positioned in its desired location taking care on which side (right or left) you want **part 2** to place for access the system. This is important in case you want to mount housings for access control units at **part 2**.
- Foundation drillings 7 x M16 as per drilling plan figure 2
- Mount threaded rod (see enclosed separate description)
- Wait till bolts are cured (see separate description)
- Mount the components in correct order (part 1, 2..) onto the foundation, however, do not tighten entirely the bolts in order to compensate any drilling offset which may occur afterwards. Use screws 6 x M 10 x35. Grease the screws before.

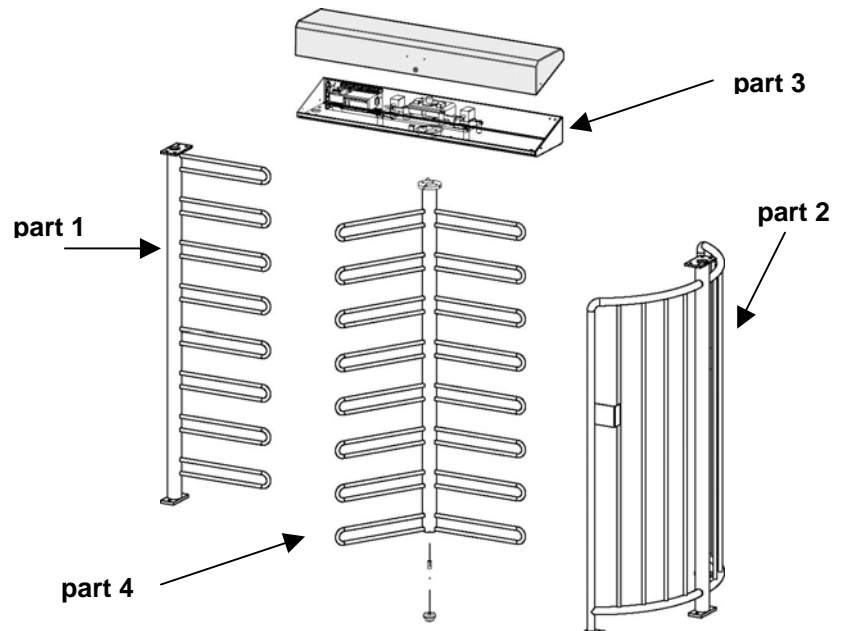

Fig.5

- Place part 3 upon part 1 and 2. Use screws 8 x M12 x 35 and counter nut.
- Mount lower bearing (see fig. 8). Using screws M10 x 70. Grease them before.
- Put part 4 on the lower bearing, see fig. 9 and screw it up by means of 4 x M16 x 40 with U-discs and flange. Be sure that the turnstile is in locked position.
- Now tighten all fixing bolts.

5.2 Fixing on foundation frame

See section 5.1 fixing the foundation.
However in this case the turnstile is mounted on the flanges of the foundation frame.
Fixing of foundation frame, see section 4.1

5.3 Opening of the top cover



Fig.6

Opening by key. The cover is secured by means of a chain.
Two keys are included in the delivery.

5.4 To fit the turnstile (above ground foundation)

Fixing of the turnstile is done by means of the 8 fixing bolts M8 and plain washer.

After final positioning tighten all bolts firmly.



Fig. 7

Note:

1. Mark the dimensions onto foundation acc. to fig.4
2. Drill
3. Install turnstile
4. screw together (see fig. 5.1)

5.5 To fit the centre column

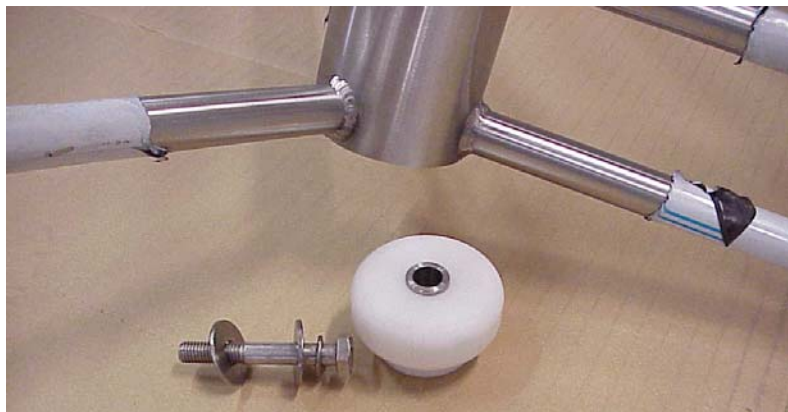

Fig. 8



Fig. 9

Mount the lower bearing on the foundation and stick the centre column on it.



Fig. 10

Fix the centre column by means of the delivered screws M16 at the top flange.
Make sure the centre is in correct position (centre in locked position).

5.6 Assembly of roof with drain

Please see fig. 11.

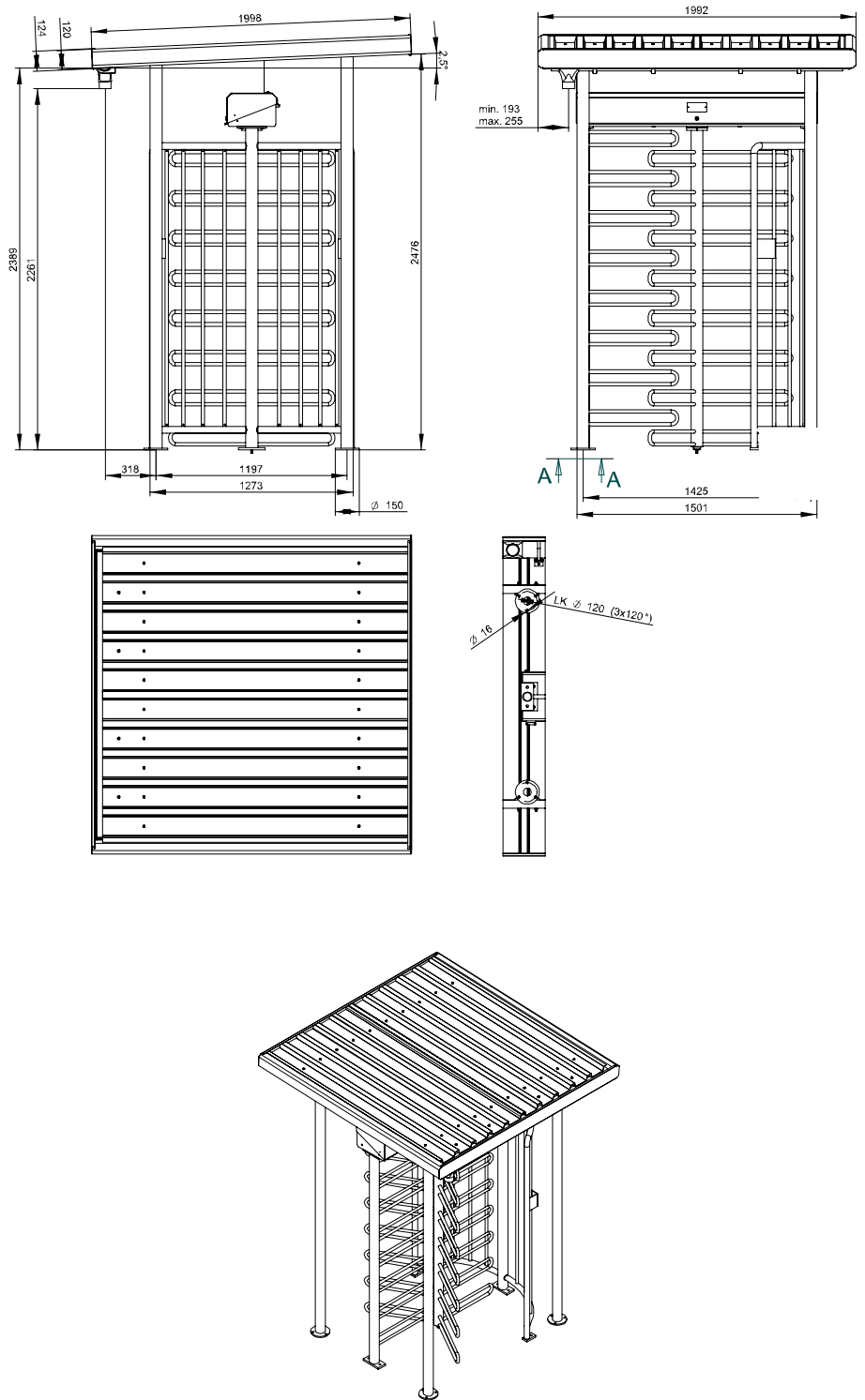

Fig.11

6. Electrical connections

Connection of mains supply should only be performed by a certified electrician and according to the connecting diagram or after discussion with the supplier.
Fig. 12

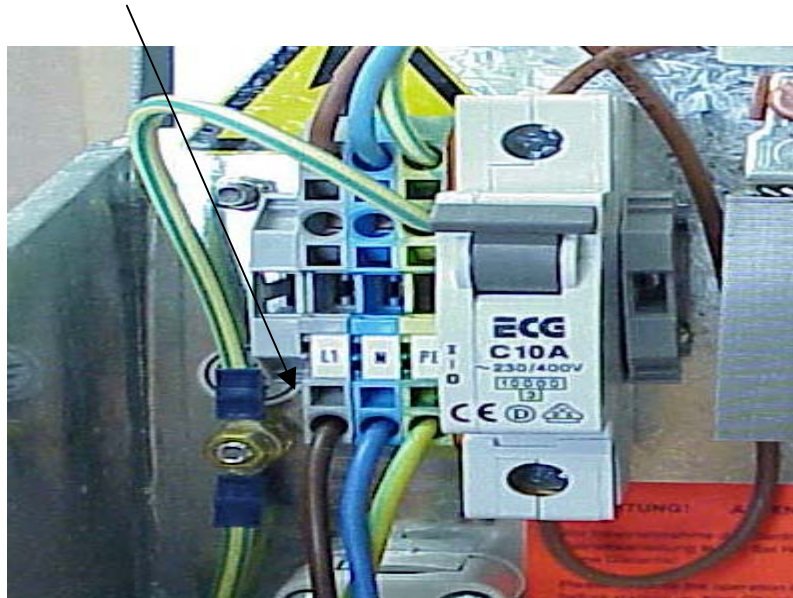

Fig. 12

Connection unit with control unit MSC10

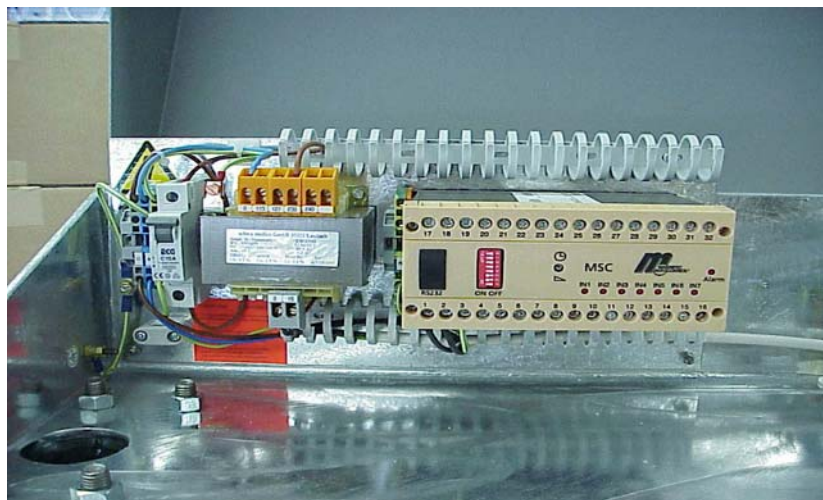

Fig. 13

6.1 Connecting diagram MSC - 10

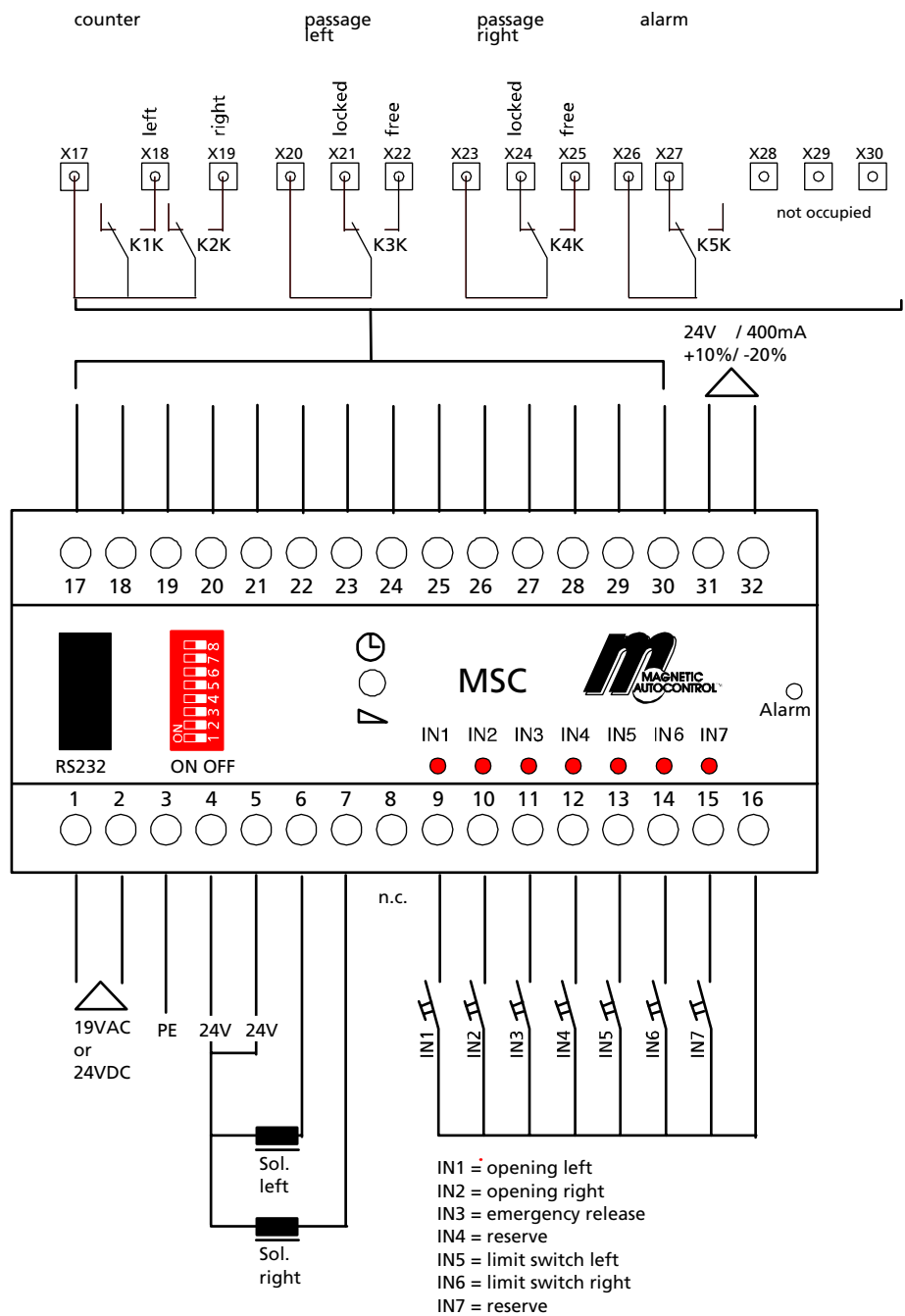

FIG.14

7. Housings / access control units

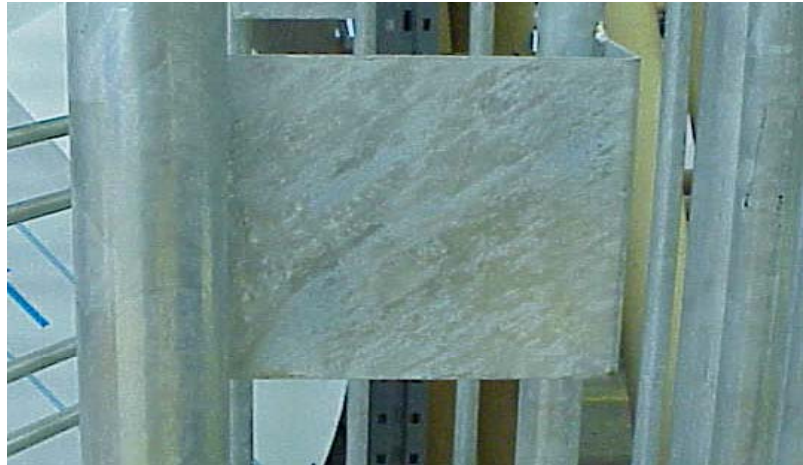

Fig. 15

Possible adaption of surface control devices

Rear side of the mounting



Lead the cable from the rear side of the mounting plate to the steel tube and drill the hole.

Here, for example

Fig. 16

8. Option

Power fail locking mechanism

This mechanism will lock the centre column in one or both directions in the event of a power failure. This requires changing of the solenoid, see fig. 17, the components are available on request (additional kit for MPT 33, ref. no. 1031,5303). The centre column can be turned freely in both directions in its standard configuration.

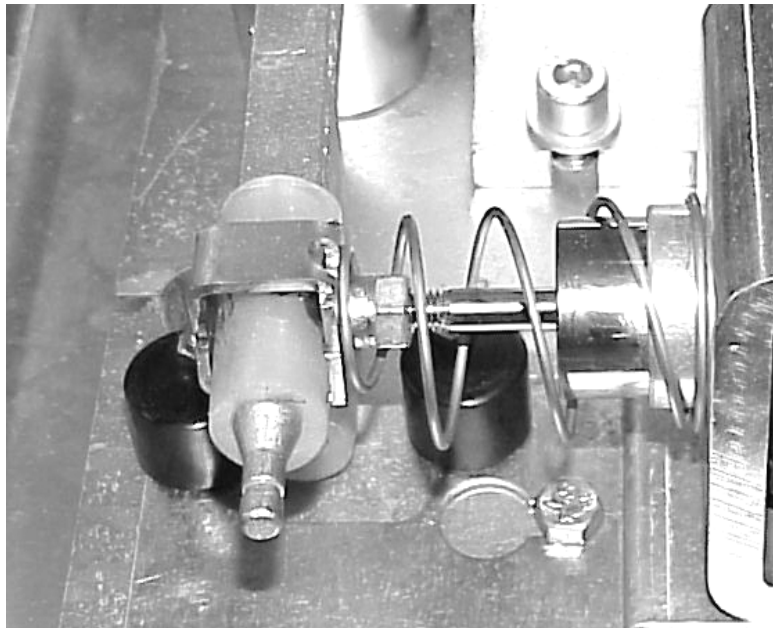

Fig.17



Warning:
Incoming mains supply and connections should only be performed by a certified electrician.

9. Commissioning

Once the mechanical and electrical installation of the turnstile has been completed, it can be put into service.

Check before startup that all assembly and installation instructions have been followed and the electrical connections have been performed correctly.

Operation of the Turnstile

The Turnstile is generally operated by an access control system or control switches.

Special control panels are also available for operation.



10. Technical Support

Should faults occur that cannot be rectified by a technician, please contact our authorised aftersales service representative.

In special cases our Technical Support is available to you: Telephone:

Please refer to the name plate on the turnstile housing for the data required in the case of queries. This is found under the mechanism cover.

11. Spare parts and accessories

See Figure 14 for the exploded drawing which details the individual parts and their identification numbers.

12. Warranty

The manufacturer reserves the right to adapt technological progress without special announcement. Magnetic will be pleased to provide up to date information and possible changes or additions to the operating instructions.

Under the precondition that the operating conditions are complied with and no inadmissible interventions have been made to the interior of the equipment and the equipment has no mechanical damage, a warranty of 2 year after delivery of the equipment applies on all mechanical and electrical components.

13. Control Unit MSC 10

Functions

13.1 Functions of digital inputs

Input 1 terminals X21 / X22 = Opening of passage direction left
Opening pulse passage left (entry).

Input 2 terminals X24 / X 25 = Opening of passage direction right
Opening pulse passage right (exit)

Input 3 IN3, terminal 11 = input emergency situation
In case of emergency passage free in both directions.

13.2 Function of semi conductor outputs

Output 1 terminal X6 = solenoid left

Output 2 terminal X7 = solenoid right

Output 3 terminal X8 = reserve

13.3 Function of relay outputs

Relay 1 = counter pulse left terminal X18

If the end position in passage direction left is reached a counter pulse of 300 ms is given. This applies to permanent release also.

Relay 2 = counter pulse right terminal X19

If the end position in passage direction left is reached a counter pulse of 300 ms is given. This applies to permanent release also.

Relay 3 = Display passage free left terminals X22 + X21

In case of free passage left a permanent signal is given. This output can also be used

to lock a pulse transmitter for passage right if passage left is given free.

Relay 4 = Display passage free right terminals X 24 + 25

In case of free passage right a permanent signal is given. This output can also be used

to lock a pulse transmitter for passage left if passage right is given free.

Relay 5 = Error-/Alarm output terminal X27

In case of certain errors a permanent signal is given as long as the error is not eliminated.

Relay 6 = Reserve

13.4 Safety functions

In case of an error in the microcontroller the watchdog function releases a hardware reset.

14. Adjustable parameters

The following parameters can be adjusted by means of DIP switches and the trimming potentiometer:

DIP	Function	OFF	ON
1	Barrier type	MPT	MPP
2	Pulse storage	Off	On = 4 pulses per direction
3	Locking delay time	Off	On = 1 sec.approx.
4	Hardware tests	*)	*)
5	Hardware tests	*)	*)
6	Solenoid left	Normal	inverted
7	Solenoid right	Normal	inverted
8	Opening duration via LEDs	No display	display

DIP 1 Selection of barrier type

One of the following barrier types must be selected:

- MPP
- MPT

At present this demand is locked; in every case barrier type MPT is selected.

DIP 2 Pulse storage

In case the function is switched-off the demand pulses from one direction only can be processed. Demand pulses from the other side are then ignored.

In case the function is switched-on max. 4 demand pulses per passage direction can be stored.

DIP 3 Locking delay time

In order to avoid a rotation of more than 120° in case of permanent release or several stored pulses a locking delay time can be activated via a dip switch. The turnstile is then locked for 1 sec. approx after rotation of 120° and will then be released for passing.

DIP 6 Solenoids

Via DIP 6 and DIP 7 the function of both solenoids can be inverted separately for both directions. This depends on whether the solenoids are integrated currentless open or closed. DIP 6 affect the left solenoid output and DIP 7 the right one.

DIP 5 Opening duration

To be adjusted via trimming potentiometer between 1 – 32 sec..

15. Operating modes

15.1 Pulse operation in both directions without pulse storage

15.2 Pulse operation in both directions with pulse storage

15.3 Permanent release in both directions

15.4 Pulse operation in one direction, permanent release in the other direction

Recommendations

Recommendation 89/392/EWG of 14.06.89 incl. modifications up to 93/68/EWG of 22.07.03

Recommendation 73/23/EWG of 19.02.73 incl. modifications up to 93/68/EWG of 22.07.03

Recommendation 89/336/EWG of 03.05.89 incl. modifications up to 93/68/EWG of 22.07.03

DIN VDE 0113 T1 06.93 (EN 60204-1-1992, IEC 204-1-1992)

DIN EN 292 T2 11.91